

English

Building & Industry

NOVENCO 

SCHAKO Group

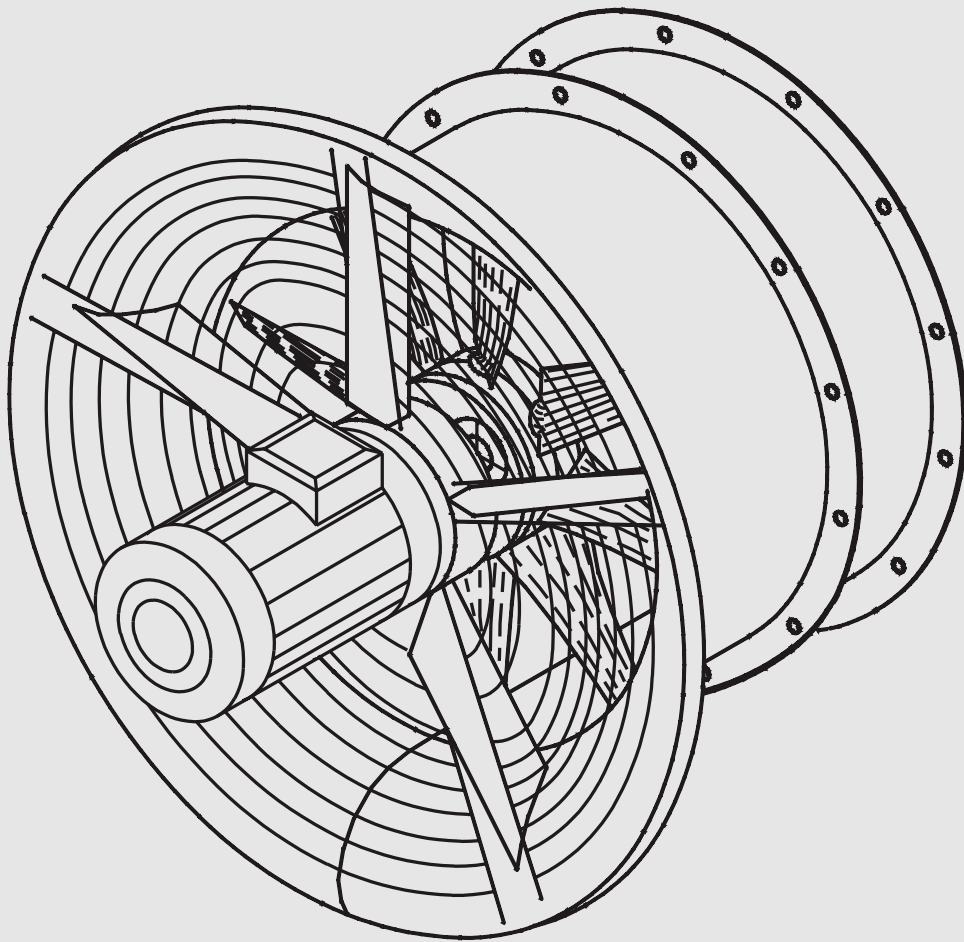

NOVENCO[®] Axial fan types

NovAx[™] ACP-ACG

Installation and maintenance

NovAx™ axial flow fans types ACP and ACG Installation and maintenance

1. Application

2. Handling

- 2.1 Marking
- 2.2 Weight
- 2.3 Transport

3. Storage

4. Installation

- 4.1 Prior to installation
- 4.2 Installation
- 4.3 Mounting brackets
- 4.4 Duct connection
- 4.5 Electric connection

5. Start of operation

- 5.1 Prior to start of operation
- 5.2 Motors with Y/ Δ -start
- 5.3 Start-up procedure

6. Maintenance

- 6.1 Prior to maintenance
- 6.2 Fan casing
- 6.3 Impeller
- 6.4 Motor
- 6.5 Dismounting of motor
- 6.6 Mounting of motor
- 6.7 Blade pitch adjustment
- 6.8 Troubleshooting

7. Sound

8. Trademarks and copyright

9. Quality and environment

10. Warranty

11. Declaration of conformity

Appendices - wiring diagrams

- A. Motors up to 16 A – delta
- B. Motors up to 16 A – star
- C. Motors over 16 A – delta
- D. Motors over 16 A – star

1. Application

Axial flow fans types ACP and ACG are compact and sturdy standard fans, suitable for conventional installations for marine and industrial ventilating applications.

2. Handling

2.1 Marking

The ACP and ACG fans are provided with a standard nameplate with Novenco's name and address. It also mentions product type, e.g. ACP 1000/380, serial No. or order No. as well as weight and fan speed.

A motor nameplate with relevant motor data is also provided.

2.2 Weight

The total weights are determined on the basis of fan type and size as well as the maximum motor size employed. See tables 1. and 2.

2.3 Transport

Axial flow fans types ACP and ACG are supplied on pallets or bearers to allow fork-lift transport.

		Motor size										
Fan size		-71	-80	-90	-100	-112	-132	-160	-180	-200	-225	-250
Hub diameters 160, 230, 280, 330 and 380	ACP 250	20.9	27.1									
	ACP 315	22.8	29	36								
	ACP 400	29.8	36	43	55.5							
	ACP 500	33.8	46	53	65.5	74	118					
	ACP 560	40.8	56	63	75.5	84	128	188				
	ACP 630	43.8	60	67	79.5	88	132	192	262			
	ACP 710	48.8	66	73	85.5	94	138	198	268			
	ACP 800	53.8	71	78	90.5	99	143	203	273			
	ACP 900	62.8	79	76	98.5	107	151	211	281			
	ACP 1000			93	105.5	114	158	218	288			
Hub diameter 403 and 578	ACP 900					131	196	256	326			
	ACP 1000					139	224	284	354	456		
	ACP 1120					151	237	297	367	451	650	
	ACP 1250						278	338	408	492	691	
	ACP 1400							357	427	511	710	802
	ACP 1600									542	741	833

Table 1. Total weights of ACP fans with motors [kg]

		Motor size										
Fan size		-71	-80	-90	-100	-112	-132	-160	-180	-200	-225	-250
Hub diameters 160, 230, 280, 330 and 380	ACG 250	24.6	30.8									
	ACG 315	27.6	33.8	40.8								
	ACG 400	37.8	46	51	63.5							
	ACG 500	44.8	58	65	77.5	86	130					
	ACG 560	52.8	70	77	89.5	98	142	202				
	ACG 630	57.8	75	82	94.5	103	147	207	277			
	ACG 710	63.8	83	90	102.5	111	155	215	285			
	ACG 800	69.8	90	97	109.5	118	162	222	292			
	ACG 900	82.8	101	108	120.5	129	173	233	303			
	ACG 1000			117	129.5	138	182	242	312			
Hub diameter 403 and 578	ACG 900					161	229	289	359			
	ACG 1000					172	261	321	391	475		
	ACG 1120					188	278	338	408	492	691	
	ACG 1250						324	384	454	536	737	
	ACG 1400							408	478	562	761	853
	ACG 1600									601	800	892

Table 2. Total weights of ACG fans with motors [kg]

Motor type	-71	-80	-90	-100	-112	-132	-160	-180	-200	-225	-250
Motor weight	12	18	25	38	46	90	150	220	304	503	595

Table 3. Motor weights according to size for four-pole motors [kg]

Lifting and transport must be done with care, as the fans are vulnerable to vibrations and shocks. These can result in imbalance and deformations. Check the blade clearance, fan casing and flanges before installation.

Lift fans preferably in three points. Fit an eyebolt on top of the motor, if the motor orientation allows, or put a strap around the motor, and use two flange holes. An eyebolt is not included in the Novenco delivery.

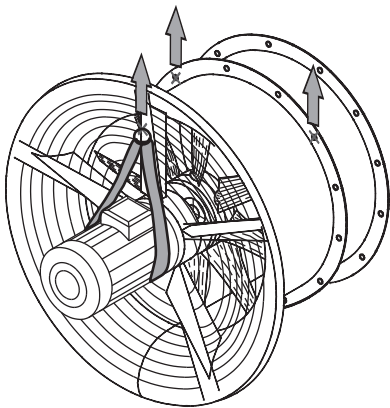

Figure 1. Lift fans in preferable three points

Large fans have lifting eyes on the back of the inlet cone. For these fans it is enough to lift in two points. Otherwise, follow the above procedure for lifting in three points.

3. Storage

Axial flow fans type ACP and ACG can stand outdoor storage for one month provided the packing is intact. Fans with no packing must be stored in a sheltered place.

If the fans are stored indoors under well-ventilated conditions without risk of condensation the storage period may be extended to six months.

The storage space must not be exposed to vibrations likely to damage the motor bearings. If the storage period exceeds three months, the impeller must be turned regularly by hand.

4. Installation

NovAx axial flow fans types ACP and ACG are designed for operation in both horizontal and vertical position. (Knowledge of installation position is required before drilling of drain holes). ACP is for free inlet and without connection to duct on the pressure side. ACG is for free inlet and connection to duct

on the pressure side. The ACG is fitted with a downstream guide vane arrangement.

4.1 Prior to installation

Prior to installation make sure that the impeller rotates freely in the fan casing. The mean blade clearance, which is the distance between the blade tip and the fan casing, must be equal to or larger than the minimum value.

Fan size	Min. clearance [mm]	Fan size	Min. clearance [mm]
250	0.3	800	0.8
315	0.3	900	0.9
400	0.4	1000	1.0
500	0.5	1120	1.1
560	0.6	1250	1.3
630	0.6	1400	1.4
710	0.7	1600	1.6

Table 4. Minimum allowable blade clearance

Calculate the mean clearance in millimetres by finding the maximum value, adding the values from three points at 90° offsets, and dividing by four.

$$\text{Mean clearance} = \frac{\text{Max.} + P1 + P2 + P3}{4}$$

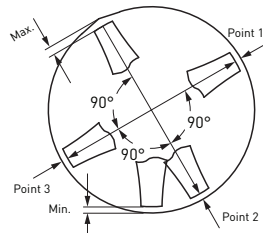

Figure 2. Calculation of mean clearance

Adjust the motor position in the suspension arrangement until it meets the minimum allowable blade clearance.

4.2 Installation

The fan is provided with an arrow-plate denoting the direction of airflow through the fan casing. See during installation that the fan is oriented so as to provide the desired direction of airflow in the system.

The best way of installing the fan is using mounting feet (available as optional extras, fig. 3), but it may also be suspended in the fan casing flanges or in special carriers.

The carriers must not hamper the free inlet and outlet flow of the air.

When the fan has been finally secured make sure that the impeller rotates freely in

the casing.

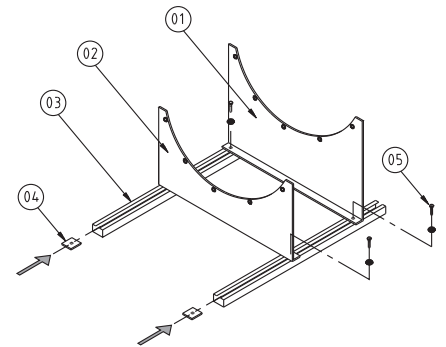

Figure 3. Mounting foot for type ACP (optional)

4.3 Mounting feet

Mounting feet for types ACP and ACG consist of two mounting plates (fig. 3, items 01 and 02). Mount two c-profiles (item 03) under these by means of bolts (item 05) and nuts (item 04).

The distance between the end of the c-profile and mounting plates is determined by type/size and motor size.

Mount the fan casing in the two flange holes of the mounting plates and mount the distance bush (fig. 4, item 07) by means of joining elements (items 08 and 09) between inlet cone and mounting plate (item 06).

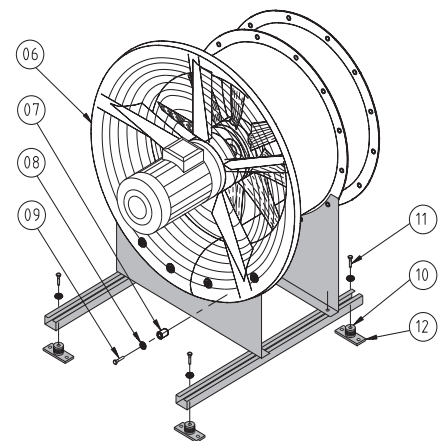

Figure 4. Mounting foot for types ACP and ACG 250-1120 (optional)

The fan houses for ACP and ACG sizes 1250 – 1600 have circular fan casings. Therefore, the fan casing is mounted with fittings for mounting foot (fig. 5, item 07A) and joining elements (fig. 5, items 08A and 09A).

Mount the fittings on the back of the mounting foot and fan casing as shown on fig. 5.

To prevent spreading of vibrations from the

fan, anti-vibration mountings may be inserted between fan and support and flexible connections fitted in the ducts after the fan. Anti-vibration mountings and flexible connections are optional extras.

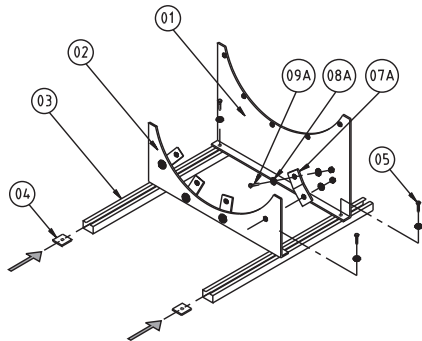

Figure 5. Mounting foot for types ACP and ACG 1250-1600 (optional)

Secure anti-vibration mountings (fig. 4, item 10) in the ends of the c-profile by means of bolts (item 11).

Mount base plates (item 12) for attachment in the foundation/floor at the bottom of the rubber element.

The natural frequency of the support must differ at least 20% from the fan speed.

If the motor is provided with drain holes for condensed water the fan must be oriented so that the holes are at the lowest point and point downwards.

It is of the utmost importance for the performance and sound level of the fan that the airflow is unimpeded and free from eddies.

4.4 Duct connection

A downstream guide vane arrangement with core can be mounted on the NovAx axial flow fan with which the fan can obtain a very high efficiency and be used for connection to duct.

The duct on the fan outlet side must be designed to ensure smooth and undisturbed flow of the air. Avoid sharp duct bends immediately after the fan.

ACP and ACG fans are prepared for circular duct connections on the outlet side.

Flanges supplied as standard comply with Eurovent 1/2.

Systems with a higher vibration level or more exacting performance requirements must be provided with expansion joints between fan and duct. The fan must not be used as support for ducts.

It is important to allow for free areas to facilitate mounting and dismantling as well as ordinary maintenance.

4.5 Electric connection

Fans fitted with drives must be installed in accordance with the EU standard for electromagnetic compatibility (EMC). The shielding and connection to ground eliminate interference and protect the motor bearings and windings. Refer to the motor documentation for methods to avoid impairment of the mains power quality. Prescribed methods may involve installation of a rectifier, filters etc.

Connection to the mains is done directly in the motor terminal box.

Connect the motor cables according to the connection diagram on the inside of the box lid. Refer also to the motor name plate as well as the order specification.

Important: The installation and connection to the supply network must be done by authorised personnel and be in accordance with current legislation.

Check the fan rotation direction once the motor is connected. Do this by briefly flicking the fan power on and off. It must comply with the arrow on the fan casing. If the direction is wrong, disconnect the main power supply and check the connections.

Reversible fans must be fitted with time delays to allow the impeller to become stationary, before changing direction. Running the fans in reverse increases the risk of stall and shortens fan life.

Important: Only fans with steel hubs may be run in reverse. Reversible operation increases risk of fan stalling. If the fan stalls, the service life is shortened.

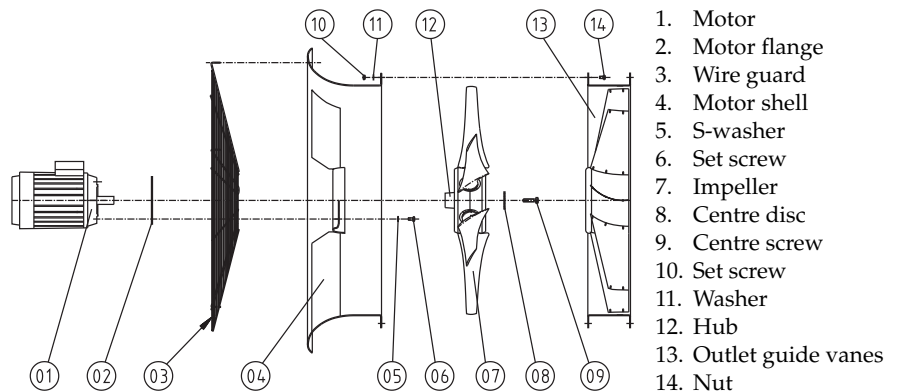

Figure 7. Dismounting/mounting of types ACG and ACP

5. Start of operation

5.1 Prior to start of operation

Prior to start of operation check that the fan and duct connections are clean and free from tools and foreign substances.

Also ensure that the electric connections meet the prescribed requirements, that any wire guard fitted on the fan inlet or outlet side is correctly mounted and that the direction of rotation of the fan complies with the arrow-plate (check by short-time operation).

See fig. 6, items 01 and 02.

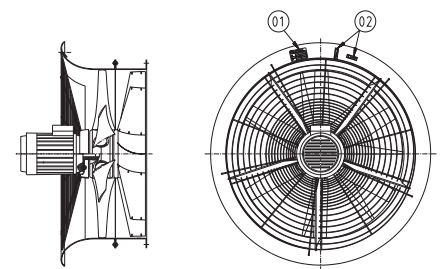

Figure 6. NovAx Type ACG

5.2 Motors with Y/Δ-start

The relay must be set to the calculated time.

5.3 Start-up procedure

- Start the fan.
- Check that no abnormal noises occur.
- See that the vibration level is normal. The vibration level at the fan operating speed must not exceed 7 mm/s, rms*, measured radially at two points, 90° offset and at the free shaft end of the motor. Otherwise, the fan must be balanced.

Operation at a vibration level exceeding 11 mm/s, rms*, is not allowed in case of fixed fan position.

Operation at a vibration level exceeding 18

mm/s, rms*, is not allowed in case of position on feet or anti-vibration mountings.

* ISO 2954, Requirements for instruments for measuring vibration severity.

After thirty minutes of operation check that the fan operates normally.

Important: The fan is designed for continuous operation. The following kinds of operation may cause fatigue break in the impeller and endanger people.

- Operation in stall area
- Operation with pulsating counter pressure - called pump mode
- Operation with repeated starting and stopping

If in doubt Novenco should be contacted to assess the suitability of the fan.

6. Maintenance

6.1 Prior to maintenance

When the fan is out of operation for reasons of inspection or repair/maintenance, the electric system must be switched off and protected so that the fan is not cut in unintentionally.

6.2 Fan casing

The fan casing requires as standard no maintenance other than ordinary cleaning.

If the fan casing is painted, the painted surface should be checked regularly and repaired where necessary.

6.3 Impeller

The impeller (rotor unit) is supplied from the factory with the blades adjusted to the pitch corresponding to the desired operating point (pressure and airflow) at the fan speed in question. To ensure vibration-free operation the impeller has been carefully balanced in this position.

Vibrations occurring during operation will normally be due to accumulations of dust or dirt on hub and blades, and will disappear after cleaning. Should this not be the case, expert assistance should be called in immediately, as continued vibrations will shorten the life of the blades and the motor bearings.

6.4 Motor

The motor normally only requires maintenance of the bearings as indicated in the maintenance instructions for electric

motors.

6.5 Dismounting of motor

Prior to commencing the work, switch off the current and disconnect the motor cable. Next, dismount any ducts and downstream guide vane arrangement (fig. 7, items 13, 10, 11, and 14) on the fan outlet side.

Remove the impeller centre screw (item 09) and centre disc (item 08).

Dismount the impeller by means of a puller fastened in the two threaded holes of the hub boss (item 12).

Detach the motor by loosening the screws in the motor shell (items 05 and 06). Now the motor (item 01) and motor flange (item 02) can be removed.

In dismounting and disassembling the fan be careful not to expose the individual parts to shocks etc. likely to damage the motor bearings or other fan components.

6.6 Mounting of motor

After servicing remount the motor, check that the motor flange (fig. 7, item 02) is correctly located and that the motor shaft is concentrically placed in the fan casing, before tightening the bolts (item 06).

Mount the impeller (item 07) on the motor shaft by means of a tool fastened in the threaded hole of the motor shaft. Fix the impeller hub to rest against the motor shaft collar.

Check that the mean blade clearance is within the minimum allowable value. See section "4.1 Prior to installation" for values and calculation of mean blade clearance.

Now mount the centre screw (item 09) and centre disc (item 08). Replace lock washers and lock nuts during fan assembly. Finally, connect the motor cable in the terminal box (item 01) and any ducts and downstream guide vane arrangement (item 13).

To start the fan follow the procedure described in section "5. Start of operation".

6.7 Blade pitch adjustment

The blade pitch has been adjusted in the factory with a special tool (fixture) to deliver the performance required by the customer/order on delivery.

If the fan performance is required to be changed it is possible to change the blade pitch. It requires knowledge of the motor load and the max. permissible blade pitch on the graph as related to the motor rating

(in case of blade pitch increase).

Contact Novenco before any such adjustment of the blade pitch.

Novenco can supply special tools for blade pitch adjustment and instructions for impeller balancing.

The brochure "Blade-angle tool" is available on request.

6.8 Troubleshooting

These are likely causes of breakdowns/failures.

Deficiency in performance

Blocked air supply to the fan inlet side

- Damper closed
- Duct choked
- Supply fan, if any, stopped
- Motor defective
- Motor cut out
- Wrong direction of rotation of impeller.

Noise/vibrations

- Bearings in electric motor defective
- Impeller out of balance
- Impeller worn/damaged
- Bolts/components loose
- Impeller blades have different pitch angles
- Fan operates in the stalling area. May result in break-down - repair failures, see "Deficiency in performance".

7. Sound

The sound generation of the fans depends on installation and operating conditions, which means that no general data of the sound generation can be given.

Reference is made to our catalogues or computer programs for calculation of the specific sound generation.

8. Trademarks and copyright

Novenco®, ZerAx®, 诺文科, 诺万科 and 诺克 are registered trademarks of Novenco A/S.

AirBox™ and NovAx™ are trademarks of Novenco Building & Industry A/S.

Other trademarks appearing in this document are the property of their respective owners.

Copyright (c) 1998 - 2016, Novenco Building & Industry A/S.
All rights are reserved.

9. Quality and environment

Novenco Building & Industry A/S is ISO 9001 and 14001 certified. All fans are inspected and tested.

10. Warranty

Novenco provides according to law a standard 12 months warranty from the product is sent from the factory. The warranty covers materials and manufacturing defects. Wear parts are not covered.

Extended warranty can be agreed upon.

11. Declaration of conformity

The Machinery Directive 2006/42/EU, part 2, A.

Novenco Building & Industry A/S
Industrivej 22
4700 Naestved
Denmark

hereby declares that axial flow fans types ACP 250-1600 and ACG 250-1600 have been manufactured in conformity with the Council's directive 2006/42/EU regarding mutual approximation of the machinery laws (the Machinery Directive) of the member states.

Directives

- Machinery 2006/42/EU
- ECO design 2009/125/EU
- ECO energy labelling 2010/30/EU
- EMC 2014/30/EU
- LVD 2014/35/EU

Applied standards and regulations

EU 327/2011

Fans driven by motors with electric power between 125 W and 500 kW

EN ISO 12100:2011

Safety of machinery

- General principles for design
- Risk assessment and risk reduction

EN ISO 13857

Safety of machinery - Safety distances

EN 60204-1

Safety of machinery - Electrical

equipment of machines Part 1:

General Requirements

EN 6100-6-2

EMC - Part 6-2: Generic standards -

Immunity for industrial

environments

EN 61000-6-3

EMC - Part 6-3: Generic standards -

Emission standard for residential,

commercial and light-industrial

environments

EN 61800-3, class C2

Adjustable speed electrical power

drive systems, EMC requirements and

specific test methods

It is conditioned for the validity of the warranty that Novenco's instructions for installation and maintenance have been followed.

Naestved 01.10.2016

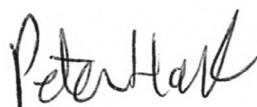

Peter Holt

Technical director

Novenco Building & Industry A/S

Appendices – wiring diagrams

A. Motors up to 16 A – delta

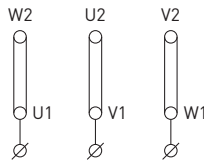

Figure 8. Terminal box delta connected for motors below 16 A

B. Motors up to 16 A – star

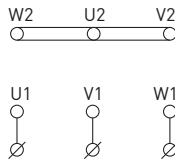

Figure 9. Terminal box star connected for motors below 16 A

C. Motors over 16 A – delta

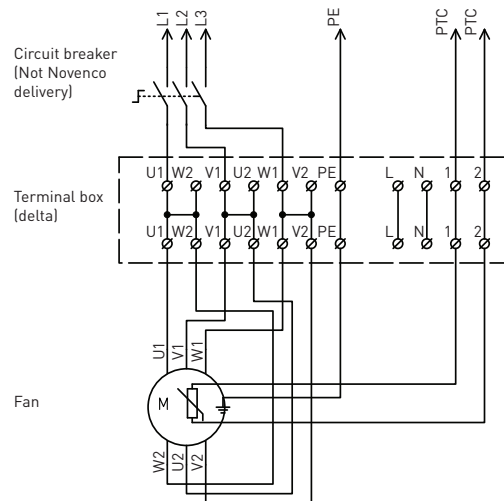

Figure 10. Terminal box delta connected and wiring diagram for motors above 16 A

D. Motors over 16 A – star

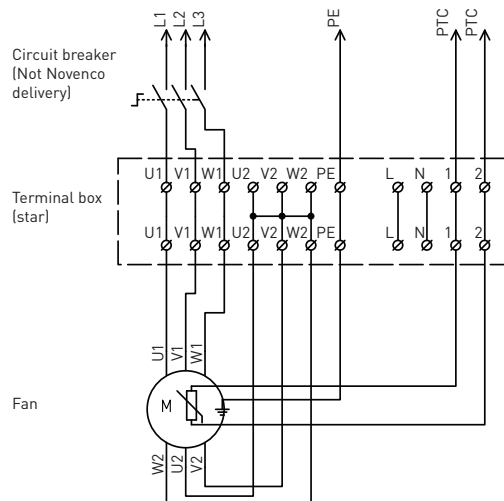
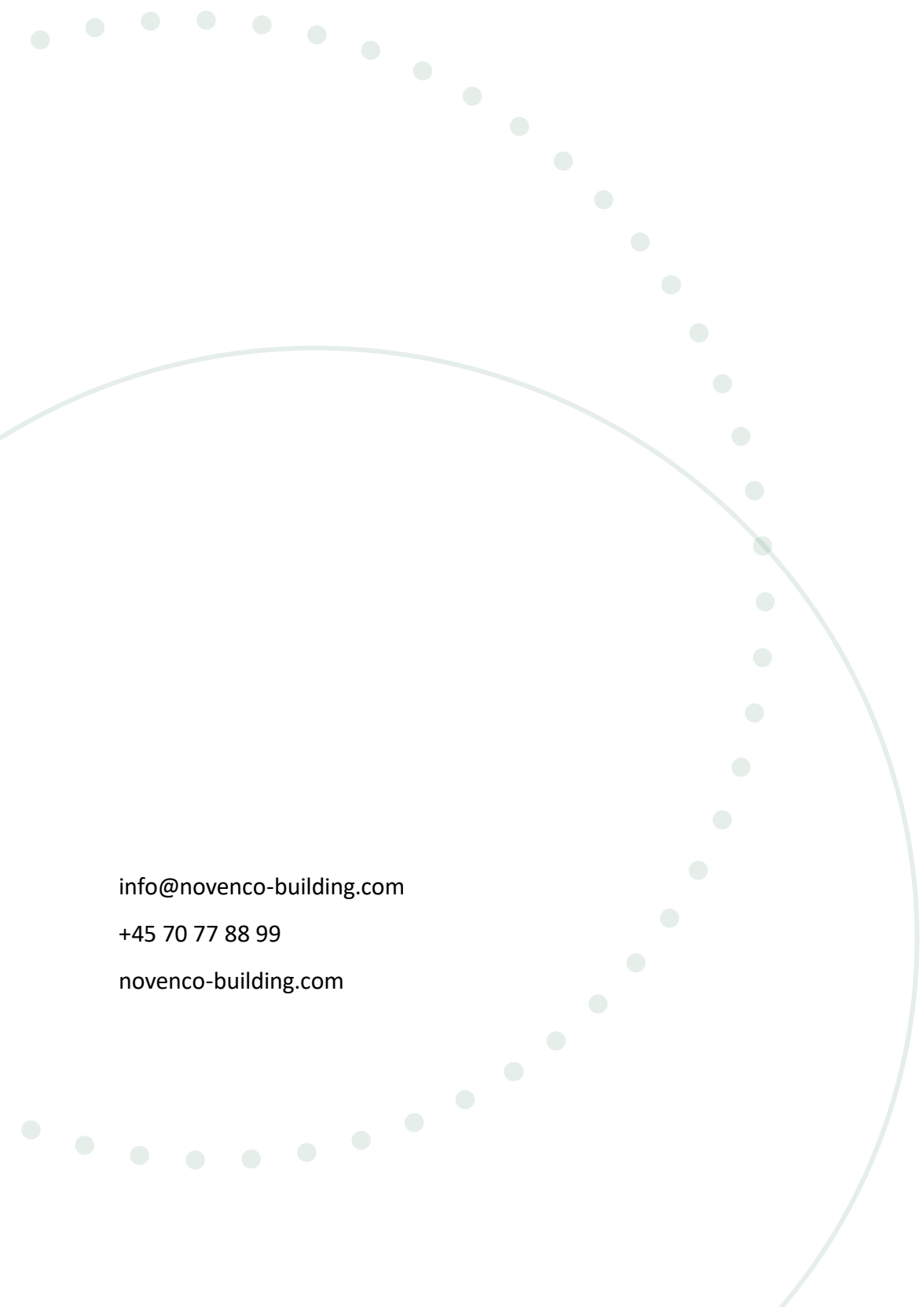

Figure 11. Terminal box star connected and wiring diagram for motors above 16 A



info@novenco-building.com

+45 70 77 88 99

novenco-building.com