

Pure competence in air.

NOVENCO® CENTRIFUGAL FANS TYPE CND-CNF INSTALLATION AND MAINTENANCE

Building & Industry

NOVENCO 

SCHAKO Group



ENGLISH

917868-0

Novenco® centrifugal Fans Types CND and CNF

Installation and maintenance

1. Application

2. Handling

- 2.1 Marking
- 2.2 Weight
- 2.3 Transport

3. Receipt

4. Storage

5. Installation

- 5.1 Fastening
- 5.2 Prior to duct connection
- 5.3 Duct connection
- 5.4 Wiring

6. Start-up

- 6.1 Prior to start-up
- 6.2 Starting procedure
- 6.3 Calculation of air volumes

7. Maintenance

- 7.1 Prior to inspection and maintenance
- 7.2 Fan casing
- 7.3 Impeller
- 7.4 Motor
- 7.5 Dismounting the motor on CND and CNF direct
- 7.6 Fault localisation
- 7.7 Belt drive
- 7.8 Bearing unit

8. Sound

9. Declaration of conformity

address as well as product type, e.g. CND 560 LG, and order number. The motor also has a nameplate.

2.2 Weight

The total weights shown in table 1 apply to CND, CNF, excl. of motor mounted direct on the motor cover plate (flange motor, B5- flange), (see figure 1.).

The weights of the individual motor sizes appear from table 2.

2.3 Transport

The fans are delivered on oversize pallets which may be arranged in a lorry side by side without the risk of damage. This allows transportation by fork lift.

3. Receipt

Upon arrival to the site the fan should be inspected for shipping damages and the consignment checked for completeness.

Important: Damages and defects must

be reported to the supplier immediately.

4. Storage

The fans may be stored outdoor for one month provided that the packing is intact. The indoor storage period in a well ventilated area without risk of condensation can be up to six months. The area must not be exposed to vibrations as this may damage the motor bearings etc. The impeller should be turned regularly by hand.

5. Installation

5.1 Fastening

The fan casing may be attached (mounted) on any of the four sides (universal installation). Please note that the fan must not be provided with motors larger than those specified in table 2. The fan must be mounted on a horizontal, solid and plane foundation to prevent deformation of the fan casing. The natural

Direct coupled

	Fan size						
	315	400	450	500	560	630	710
CND/F	40	59	77	84	113	153	187

Belt drive

	315	400	450	500	560	630	710
Motor on casing	62	78	100	118	165	206	255
Motor on bracket	71	87	116	132	194	234	282

Table 1. Total weights excl. motor [kg]

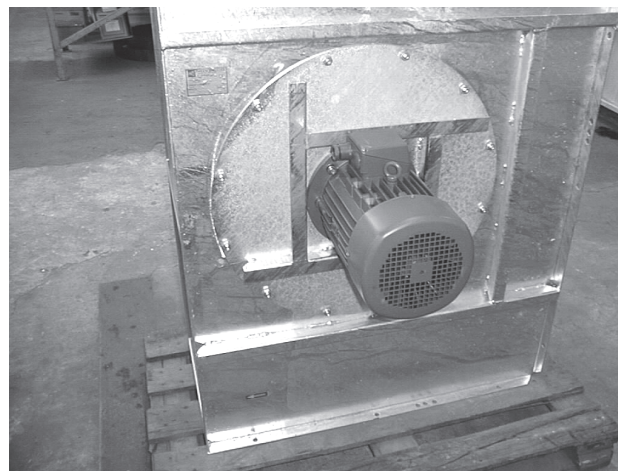

Figure 1. Motor mounted direct on the motor cover plate

The max. permissible weight appears from table 2.

The current motor weight depends on make and motor size.

1. Application

Centrifugal fans types CND and CNF, are compact low-pressure fans designed for universal installation, i.e. the positions 0, 90, 180 and 270°.

CND and CNF are primarily used for process air in industrial and composting plants, but also for other installations in light aggressive environments, including marine and off-shore environments.

2. Handling

2.1 Marking

The fan is provided with a standard nameplate with Novenco's name and

frequency of the foundation must be at least 20% higher than the highest rotational frequency of the fan.

To prevent spreading of vibrations the fans are usually mounted on anti-vibration mountings. In situations where a base frame is fitted to the fan casing, the mountings must be displaced to distribute the forces evenly. See table 4 and figure 2.

Important: Make sure the anti-vibration mountings are suited for the fan, motor size and intended operation.

During installation do not expose the fan to mechanical stress, particularly when no anti-vibration mountings or flexible connections are installed.

Direct coupled		
Fan size	Max. motor size	Weight [kg]
315	112	40
400	132	70
450	132	70
500	132	70
560	160	140
630	160	140
710	180	190

Belt drive		
Fan size	Max. motor size	Weight [kg]
315	132	70
400	132	70
450	160	140
500	160	140
560	160	140
630	180	190
710	200	255

Table 2. Max. permissible motor size

Fan size	A	B
315	100	375
400	100	440
450	125	510
500	125	570
560	125	680
630	125	725
710	125	840

Table 3. Location of anti-vibration mountings.

Direct coupled

Fan size CND/F	Choice of anti-vibration mountings – Motor size						
	80	90	100	112	132	160	180
315	AD2015 White	AD2015 White	AD2015 Red	AD3025 White			
400	AD2015 Red	AD2015 Red	AD3025 White	AD3025 White	AD3025 Red		
450	AD3025 White	AD3025 White	AD3025 White	AD3025 Red	AD3025 Red		
500	AD3025 White	AD3025 White	AD3025 White	AD3025 Red	AD3025 Red		
560			AD3025 Red	AD3025 Red	AD4030 White	AD4030 Red	
630			AD4030 White	AD4030 Red	AD4030 Red	AD4030 Red	
710				AD4030 Red	AD4030 Red	AD5035 Red	AD5035 Red

Belt drive

Fan size CND/F	Choice of anti-vibration mountings – Motor size							
	80	90	100	112	132	160	180	200
315	AD2015 Red	AD3025 White	AD3025 White	AD3025 White	AD3025 White			
400	AD3025 White	AD3025 White	AD3025 White	AD3025 Red	AD3025 Red			
450	AD3025 Red	AD3025 Red	AD3025 Red	AD3025 Red	AD4030 White	AD4030 White		
500	AD3025 Red	AD3025 Red	AD3025 Red	AD4030 White	AD4030 Red	AD4030 Red		
560			AD4030 Red	AD4030 Red	AD4030 Red	AD5035 Red		
630			AD4030 Red	AD4030 Red	AD4030 Red	AD5035 Red	AD5035 Red	
710				AD4030 Red	AD5035 Red	AD5035 Red	AD7535 White	AD7535 White

Table 4. Choice of anti-vibration mountings – Basis is 4-pole standard motor – 80% damping

Installation type 1

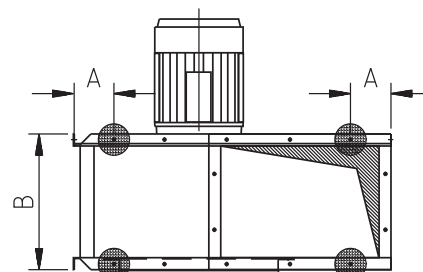

Installation type 2 – unit on base frame

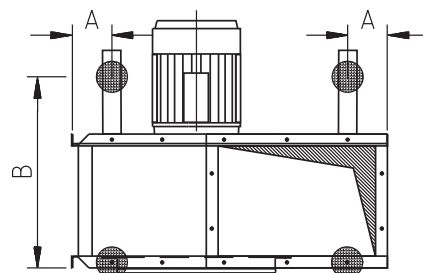

Figure 2. Location of anti-vibration mountings.

5.2 Prior to duct connection

Prior to duct connection check that all moving parts are able to move freely and that the distance between impeller and

inlet cone is approximately the same all around the circumference. Also check that the fan and adjacent ducts are clean and cleared of foreign bodies.

5.3 Duct connection

To prevent fan vibrations from propagating to the surrounding duct system, flexible connections may be mounted between fan and ducts (accessories). The flexible connections must be loosely extended and the duct connections must be centred to the inlet and outlet fan openings and supported so that they do not hang in the flexible connections. Also ducts mounted without flexible connections must be supported so that the weight does not affect the fan casing.

Ducts must be designed to ensure smooth and undisturbed air flow. Avoid, for example, sharp bends immediately before and after fan inlets and outlets as they may result in increased

sound levels and reduced capacity.

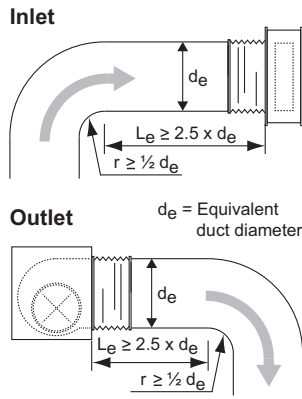

Figure 3. Example of optimal installation

Fans without duct connections on the inlet or outlet openings must be provided with wire guards (accessories) according to current regulations to shield against the impeller.

5.4 Wiring

Connection to the mains must be effected by authorised personnel. The fan must be provided with a safety switch to be switched off before working on the fan.

6. Start-up

6.1 Prior to start-up

Check the following.

- the electric connections meet current regulations
- all protective guards are mounted, i.e. inspection door, wire guards at free inlet and outlet openings
- fans mounted on anti-vibration mountings may move without affecting flexible connections and electric connections
- the fan rotation direction complies with the arrow plate - this may be checked by short-time operation.

6.2 Starting procedure

- Start the fan.
- Check that no abnormal mechanical noises or pulsations occur.
- Check that the vibration level is normal. This is important if the motor is not installed by Novenco. In that case, measure the effective vibration velocity. It must not exceed 7.1 mm/s, rms, measured at the motor.
- After 30 minutes of operation check that the fan operates normally.

6.3 Calculation of air volumes

The volume flow through the fan is calculated with the following formula and coefficients.

$$V = D^3 \times n \times (a + b \times P'^2 + c \times P'^4 + d \times P'^6 + e \times P'^8 + f \times P'^{10} + g \times P'^{12})$$

Where

- V : Volume flow [m³/s]
- D : Nominal impeller diameter [m]
- n : RPM
- P : Static pressure over fan [Pa]
- ρ : Air density [kg/m³]

$$V' : V' = \frac{V}{\frac{D^3}{n}}$$

$$P' : P' = \frac{P}{\frac{D^2}{n^2 \times 1.2 \rho}}$$

	Duct on pressure and suction side ¹	Free inlet and duct on pressure side ²
a	9,059E-01	8,916E-01
b	-6,847E-03	-2,810E-02
c	-3,829E-03	-6,427E-04
d	4,640E-04	2,883E-04
e	-2,399E-05	-2,067E-05
f	5,794E-07	5,968E-07
g	-5,366E-09	-6,239E-09

Table 5. Calculation coefficients

1. Static pressure on suction side 1xD from fan and on pressure side 2-3xD from fan
2. Static pressure on suction side (velocity = 0) and in duct 2-3xD from fan

7. Maintenance

7.1 Safety precautions prior to inspection and maintenance

When the fan is shut down for inspection or repair/maintenance, the electrical system must be switched off and secured to ensure that the fan cannot be restarted unintentionally.

7.2 Fan casing

The fan casing is maintenance-free and requires just ordinary cleaning.

7.3 Impeller

The impeller has been carefully balanced at the factory to ensure vibration-free operation. Vibrations occurring during operation will normally be due to dust deposits on the impeller and disappear af-

ter cleaning. If not, expert assistance should be called immediately, as vibrations may reduce the bearing life.

7.4 Motor

Normally only the motor bearings have to be cleaned and greased according to the instructions of the supplier.

7.5 Dismounting the motor on CND and CNF direct

Replacing the motor with another with a different number of poles, means checking that the motor speed is within the max. permissible stated on the fan nameplate. Also check that the motor rating is sufficient to cope with the change in power consumption. For motors with frequency converter also check the speed and power consumption as for motor replacement. When a frequency converter is installed, ensure that the frequency range does not result in a vibration level exceeding 7.1 mm/s. This is done by running the fan through all speeds in the regulation area and noting the vibration levels. Block the areas in the frequency converter where the vibration levels exceed the permissible level. Refer to the documentation on the converter.

When mounting the motor, the impeller must be centred carefully in relation to the inlet cone by means of the three 5 mm screws fitted in the inlet cone for fastening in the side plate.

An easy method

Dismount the motor by removing the motor cover plate (on the spiral casing). Remember to mark the exact location of the cover plate on the spiral casing before removing it. After this the cover plate including motor and impeller can be pulled out and the dismounting of the impeller can begin. This is done by loosening and removing the centre screw on the impeller hub. Pull off the impeller of the motor shaft (threaded holes for puller are in the hub) and dismount the motor from the motor cover plate.

A more difficult method

Dismount the motor by removing the duct spigot and inlet cone and loosening the centre screw on the impeller hub. After this pull off the impeller of the motor shaft (threaded holes for puller are in the hub) and dismount the motor from the motor cover plate. After removing the duct spigot and inlet cone, check that the tightening strip is intact when remount-

ing them. When dismantling and subsequently mounting the inspection door it is important that the packing is airtight.

When remounting the duct connection and the inlet cone after dismantling, check that the sealing strip is intact. When remounting the inspection door after dismantling, see that the seal is airtight.

7.6 Fault localisation

Listed below are some possible reasons for operating failures.

Reduced capacity

- Air intake on the fan inlet side blocked
- Damper closed
- Duct blocked
- Installation conditions resulting in poor air flow to the impeller
- Wrong impeller rotation direction
- Motor defective
- Motor cut out
- No/or too much overlap between impeller and inlet cone, see figure 4 and table 6.

Noise/vibrations

- Defective motor bearings
- Impeller out of balance
- Worn/damaged impeller
- Loose screws/components
- Wrong impeller rotation direction.

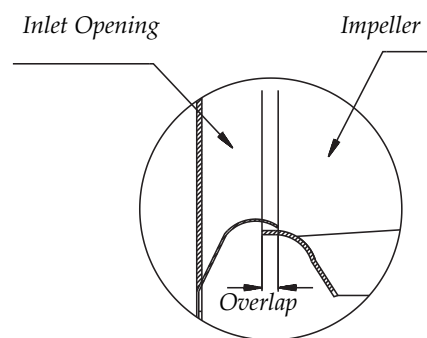

Figure 4. Sketch of overlap

Fan size	Overlap (impeller/ inl.cone)	Tolerances
315	8	-2 / +2
400	10	-3 / +2
450	11.5	-4 / +2
500	13	-4 / +2
560	14	-5 / +2
630	16	-5 / +2
710	18	-5 / +2

Table 6. Overlap [mm]

7.7 Tensioning and changing of belts

Power transmission

Installation and maintenance instructions for Optibelt V-belt transmissions

Do not forget the normal safety measures

Prior to working on the transmission, cut off the power supply and make sure that the transmission cannot be switched on while work is taking place.

V-belt pulley with TB bushes

Before installation check that all components are undamaged.

Installation

1. All shiny surfaces should be clean and free of grease.
2. Hang belt pulley over shaft and after that mount bush.
3. Turn belt pulley until all threaded holes are aligned with plain holes in bush.
4. Oil Allen screws prior to screwing them into holes and tighten so that belt pulley can still be moved on shaft.
5. For correct centring of bush and belt pulley, it is necessary to tighten Allen screws in several operations, a torque

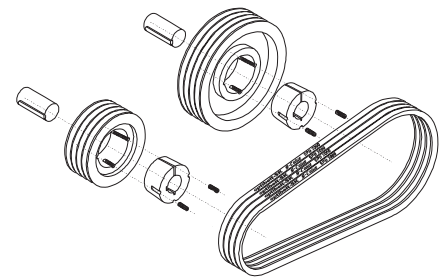

Figure 5.

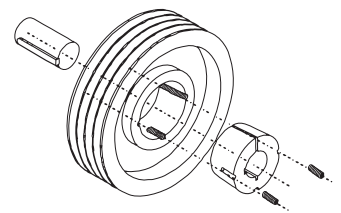

Figure 6.

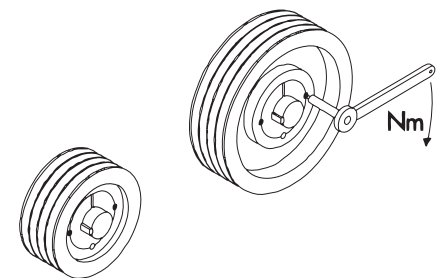

Figure 7.

wrench is very useful for this purpose.

6. Only tighten screws to torque values given for current bush, or it cannot be removed later on without using force.

Bush No.	Allen wrench	Number of screws	Tightening torques (Nm)
TB 1008, 1108	3	2	5,7
TB 1210, 1215, 1310, 1610, 1615	5	2	20,0
TB 2012	6	2	31,0
TB 2517	6	2	49,0
TB 3020, 3030	8	2	92,0
TB 3525, 3535	10	3	115,0
TB 4040	12	3	172,0
TB 4545	14	3	195,0
TB 5050	14	3	275,0

Table 7. TB bushes, Allen screws and tightening torques

Figure 8.

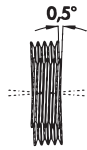

Horizontal alignment of shafts

Motor and machine shaft may have to be aligned with a machine spirit level.

Note!

Maximum misalignment 0.5°

Figure 9.



Vertical alignment and check of belt pulleys

Check the alignment of the pulleys by means of a guide rail.

Note!

After tightening screws in bushes check alignment and correct until it is in order.

Figure 10.

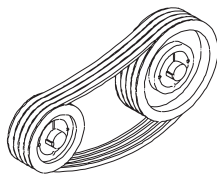

Installation of V-belts

Always place V-belts carefully on pulleys, do not force them over the edge of the pulleys.

V-belts installed by force will often only work for a few weeks and then they will have to be replaced again!

Figure 11.

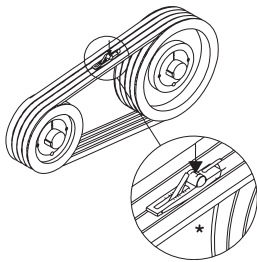

Tensioning of V-belts

The optimized values are calculated in connection with dimensioning and data sheets! The values in table 9. on page 7 presuppose that the number of belts is correct. If there are too many belts, the shaft load is increased correspondingly! Align the motor parallel by means of tension gauges at motor placed on casing or on bracket until the correct belt tension T_{min}/T_{max} is reached. Rotate the transmission a few times before checking the T_{min}/T_{max} values and adjust until the T_{min}/T_{max} values are correct. Check the belt tension the first time after 1/2 - 4 hours of operation under full load.

NB! This check is not necessary for Red Power maintenance free narrow V-belts.

** Optikrik tension gauge, see instructions on pages 6 and 7.*

Belt tension

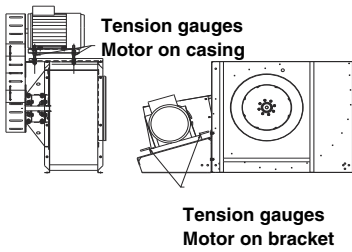

Maximum misalignment

When the belts are correctly tightened it is not certain that the belt pulleys are aligned. Do not exceed the stated X_1/X_2 maximum values for misalignment.

Other pulley sizes are interpolated.

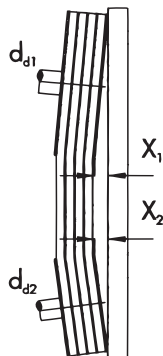

Pulley diameter d_{d1}, d_{d2} [mm]	Max. values X_1, X_2 [mm]
112	0,5
224	1,0
450	2,0
630	3,0
900	4,0
1100	5,0
1400	6,0
1600	7,0

Figure 12.

Table 8. Maximum misalignment values

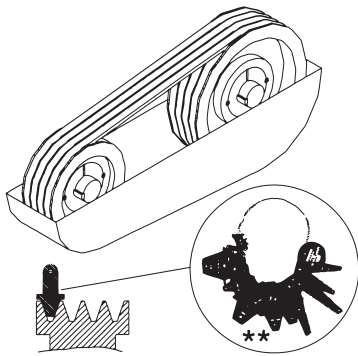

Figure 13.

Inspection of belt transmission

Check the belt tension regularly, e. g. every three/six months and tighten as required. **NB!** This check is not necessary for RedPower maintenance free narrow V-belts. Check the belt pulleys regularly for wear and tear, e. g. once a year and always before installing new belts.

Changing belt pulleys with TB bushes (see page 4 as well).

1. Loosen and remove Allen screws. Now insert Allen screws in the threaded holes intended for dismantling, tighten until the belt pulley can be removed.
2. Remove TB bush and belt pulley.

** section and pulley groove template

Tension gauges

Optikrik 0, I, II, III tension gauges (figures 14 and 15)

This tool is indispensable, if you want optimum life and efficiency of the belt transmissions. At the same time the shaft load is optimized so that it corresponds with the values stated by Optibelt. If there are no computer calculation or data sheet, you can find the maximum belt tension permitted by Optibelt in table 9 on page 7.

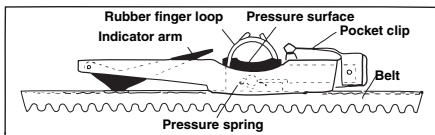

Figure 14.

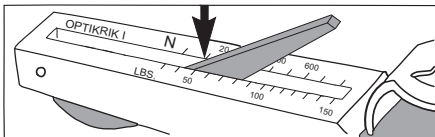

Figure 15.

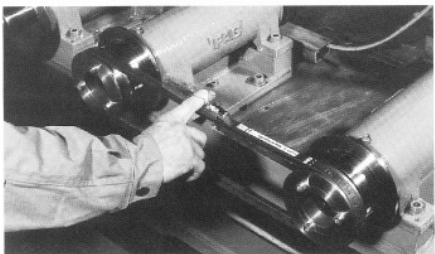

Figure 16.

Optikrik 0, I, II, III tension gauges – operating instructions (figure 16)

1. Turn transmission a few times so that tension is distributed in the entire belt before making measurements.
2. Place tension gauge on top of belt between belt pulleys, press indicator arm fully onto the scale.
3. Do not touch tension gauge with more than one finger during measuring process.
4. Now activate tension gauge by pressing a finger slowly on to the pressure surface until a click is heard/felt, immediately release pressure after click.
5. Carefully lift tension gauge from belt and read belt tension at exact point where top surface of indicator arm crosses scale.
6. Adjust belt tension until measured and stated values are identical, do not forget to turn transmission a few times after each adjustment of belt tension.

This tension gauge is only used in multi-rib belt drives when the values exceed what is measurable by means of Optikrik III. (figure 17)

1. Hang test hook (A) on belt between belt pulleys.
2. Turn second hook (B) over next belt and reset.
3. Pull handle until right test force on scale (C) is reached.
4. Now belt tension can be read as deflection depth on scale (D).
5. Adjust belt tension until measured and stated values are identical.

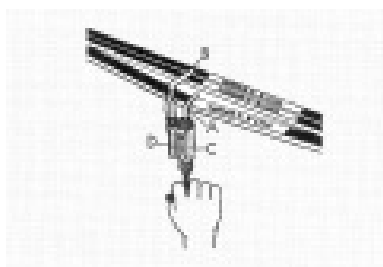

Figure 17.

Belt tension values

Belt profile	Diameter of smallest pulley (mm)	Static tension T_{max} (N)					
		Optibelt Red Power maintenance free narrow V-belts		Optibelt SK/VB wrapped narrow and classical V-belts		Optibelt Super TX moulded cogged raw edge V-belts	
		Installation new belts	Remounting same belt	Installation new belts	Control	Installation new belts	Control
SPZ; 3V/9V XPZ; 3VX/9NX	≤ 71	250	200	200	150	250	200
	> 71 ≤ 90	300	250	250	200	300	250
	> 90 ≤ 125	400	300	350	250	400	300
	>125 *						
SPA XPA	≤ 100	400	300	350	250	400	300
	>100 ≤ 140	500	400	400	300	500	400
	>140 ≤ 200	600	450	500	400	600	450
	>200 *						
SPB; 5V/15N; XPB; 5VX/15NX	≤ 160	700	550	650	500	700	550
	>160 ≤ 224	850	650	700	550	850	650
	>224 ≤ 355	1000	800	900	700	1000	800
	>355 *						
SPC XPC	≤ 250	1400	1100	1000	800	1400	1100
	>250 ≤ 355	1600	1200	1400	1100	1600	1200
	>355 ≤ 560	1900	1500	1800	1400	1900	1500
	>560 *						
Z/10; ZX/X10	≤ 50	-	-	90	70	120	90
	> 50 ≤ 71			120	90	140	110
	> 71 ≤ 100			140	110	160	130
	>100 *						
A/13; AX/X13	≤ 80	-	-	150	110	200	150
	> 80 ≤ 100			200	150	250	200
	>100 ≤ 132			300	250	400	300
	>132 *						
B/17; BX/X17	≤ 125	-	-	300	250	450	350
	>125 ≤ 160			400	300	500	400
	>160 ≤ 200			500	400	600	450
	>200 *						
C/22; CX/X22	≤ 200	-	-	700	500	800	600
	>200 ≤ 250			800	600	900	700
	>250 ≤ 355			900	700	1000	800
	>355 *						
* Belt tension values must be computer calculated.			The table does not replace a computer calculation or data sheet! The values can be used when no computer calculation or data sheet with optimized values are available (see page 5), they are based on maximum power transmission and also state maximum shaft load.				
Tension gauges			Range of application				
Optikrik 0	Area:	70 - 150 N	Narrow V-belts		Belt speed $v = 5$ to 42 m/s		
Optikrik I	Area:	150 - 600 N	Classical V-belts		Belt speed $v = 5$ to 30 m/s		
Optikrik II	Area:	500 - 1400 N					
Optikrik III	Area:	1300 - 3100 N					

Table 9. Belt tension values for Optibelt V-belts

7.8 Bearing unit

The belt driven fans are provided with a bearing unit.

The bearing unit consists of two flanged bearings (1) and shaft (2), where each flanged bearing is mounted on a base plate (3) in the bearing bracket.

The bearing housing is dust and water-tight and the bearings cannot be relubricated. In special cases the bearing housing and bearings can be changed so that relubrication is possible.

When changing the bearings first remove belt guard, V-belt and fan belt pulley.

Before dismantling the bearings, measure the distance between bearing and end of shaft (X), in order to be able to place the bearings in the same position. Loosen the hexagon-headed screws (4), mounted in the bearing housings and remove the screws in the base plate (5).

Now the base plate with bearing housing can be pulled out.

After mounting the new bearings the impeller must be carefully centred in relation to the inlet cone.

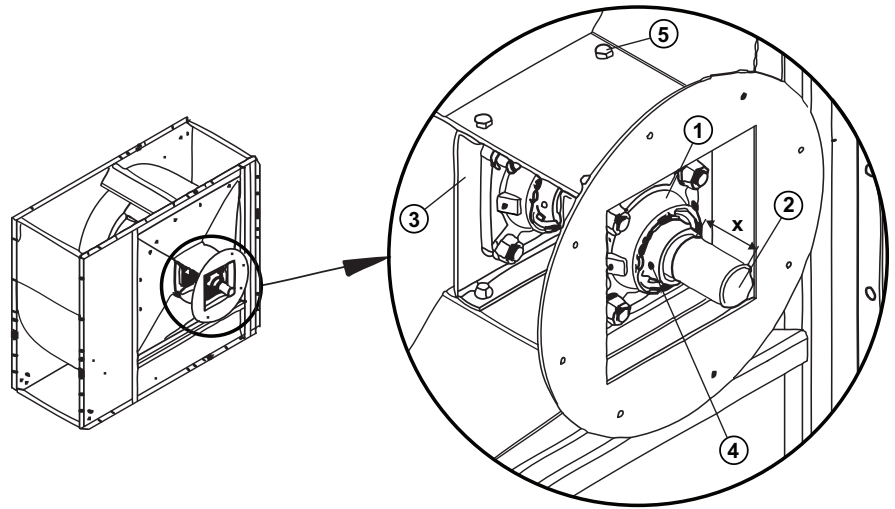

Figure 18. Disassembly of bearing unit

Type /Size	Bearing housing	Bearing	Shaft	
			Drawing No.	Bearing diameter [mm]
CND/F 315/400	FY 30 TF	YAR 206 2F	30012762	30
CND/F 450/500	FY 40 TF	YAR 208 2F	30012763	40
CND/F 560/630	FY 50 TF	YAR 210 2F	30012764	50
CND/F 710	FY 65 TF	YAR 213 2F	30012765	65

Table 10. Bearing types and shafts

8. Sound

The sound generation of the fan is dependent on the installation and operating conditions, meaning that it cannot be specified exactly.

For calculation of specific sound generation refer to our catalogue and the Air-Box computer programme.

9. Declaration of conformity

Novenco Building & Industry A/S
Industrivej 22
4700 Naestved
Denmark

hereby declares that Novenco centrifugal fan types CND/F 315-710 have been manufactured in accordance to the below directives of the European Council and that they comply with the below standards and regulations.

Directives

- Machinery 2006/42/EU
- ECO design 2009/125/EU and regulation 2017/1369/EU
- EMC 2014/30/EU
- LVD 2014/35/EU

Applied standards and regulations

- ANSI/AMCA 300-14
- EU regulation 327/2011
- DS 447:2013
- DS/EN 1037 + A1:2008
- DS/EN ISO 1461:2009
- DS/EN 1886:2008
- DS/EN 1993-1-1 + AC:2007
- DS/EN ISO 5801:2017
- DS/EN ISO 9001:2015
- EN ISO 12100:2011
- DS/EN ISO 12499:2009
- DS/EN ISO 12944-2:2017
- DS/EN 13053 + A1:2011
- ISO 13348:2007, class AN3
- DS/EN ISO 13857:2008
- DS/EN ISO 14001:2015
- DS/ISO/TR 14121-2:2012
- ISO 14694:2003
- ISO 20607:2019
- DS/ISO 21940-11:2016
- DS/ISO 21940-14:2012
- DS/EN 60204-1:2006 + A1:2009
- DS/EN 61000-6-1:2007
- DS/EN 61000-6-2:2005
- DS/EN 61000-6-3:2007 + A1:2011
- DS/EN 61000-6-4:2007 + A1:2011
- DS/EN 61800-3:2005, class C2 + A1:2012

This declaration is valid, provided that the installation and maintenance instructions are followed. Changes to the product without prior consultation with Novenco Building & Industry A/S invalidates the declaration and warranty.

Naestved, 01.07.2020

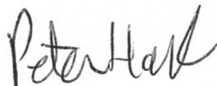

Peter Holt
Technical director
Novenco Building & Industry A/S

Pure competence in air.

Building & Industry

NOVENCO 

SCHAKO Group

WWW.NOVENCO-BUILDING.COM