

Pure competence in air.

NOVENCO® AXIAL FAN TYPES NOVAX™ ACP-ACG SMOKE INSTALLATION AND MAINTENANCE

Building & Industry

NOVENCO 

SCHAKO Group



ENGLISH

918816-0

Novenco® axial fan types NovAx™ ACP-ACG Smoke Installation and maintenance

1. Applications

2. Handling

- 2.1 Marking
- 2.2 Weight
- 2.3 Transport

3. Storage

4. Installation

- 4.1 Mounting
- 4.2 Before installation
- 4.3 Installation
- 4.4 Mounts
- 4.5 Duct connection
- 4.6 Wiring

5. Start-up

- 5.1 Before start-up
- 5.2 Motors with Y/Δ start
- 5.3 Start-up procedure

6. Maintenance

- 6.1 Safeguards before inspection and maintenance
- 6.2 Fan housing
- 6.3 Impeller
- 6.4 Motor
- 6.5 Detaching the motor
- 6.6 Fitting the motor
- 6.7 Blade pitch adjustment
- 6.8 Fault finding

7. Testing functionality and operational readiness

- 7.1 Periodic inspection

8. Sound

9. Declaration of conformity

1. Applications

NovAx smoke fans, types ACP and ACG Smoke, are compact, sturdy axial flow fans suitable for meeting both everyday ventilation requirements under normal conditions and for extracting smoke/heat in case of fire in all types of commercial and industrial buildings.

NovAx smoke fans, types ACP and ACG Smoke, are tested and approved, meeting the requirements on fans for smoke extraction in Class F300 (300°C for 60 minutes) in accordance with EN 12101-3.

2. Handling

2.1 Marking

ACP and ACG Smoke fans are provided with nameplates stating Novencoand address and details of fan type/size, e.g. ACG Smoke 1000/380, number of blades,

year of manufacture, weight, serial number/order number. The nameplate also states maximum temperature and operating time. If the fan has an approval number, the nameplate states class/category and the applicable test standard (EN 12101-3). Finally, the nameplate states

	Fan size	Motor size									
		-90	-100	-112	-132	-160	-180	-200	-225	-250	-280
Hub diameter 160, 230, 280, 330 and 380	400	38	48								
	500	48	58	66	81						
	560	58	68	76	91	168					
	630	62	72	80	95	172	204				
	710	68	78	86	101	178	210				
	800	73	83	91	106	183	215				
	900	81	91	99	114	191	223				
	1000	88	98	106	121	198	230				
Hub diameter 403	900				138	215	162				
	1000				146	223	255				
	1120			143	158	235	267				
	1250			185	200	277	309				
	1400				217	294	326				
Hub diameter 578	900				163	240	272				
	1000				185	262	294	382			
	1120			187	202	279	311	399	484		
	1250			226	241	318	350	438	523	608	
	1400					337	369	457	542	627	777
	1600							488	573	658	808

Fig. 1. Total weight of ACP Smoke fans incl. motor [kg]

	Fan size	Motor size									
		-90	-100	-112	-132	-160	-180	-200	-225	-250	-280
Hub diameter 160, 230, 280, 330 and 380	400	46	56								
	500	60	70	78	93						
	560	72	82	90	105	182					
	630	77	87	95	110	187	219				
	710	85	95	103	118	195	227				
	800	92	102	110	125	202	234				
	900	103	113	121	136	213	245				
	1000	112	122	130	145	222	254				
Hub diameter 403	900				168	245					
	1000				179	256	288				
	1120			180	195	272	304				
	1250			272	242	319	351				
	1400				263	340	372				
Hub diameter 578	900				192	269	301				
	1000				224	301	333	421			
	1120			226	241	318	350	438	523		
	1250			272	287	364	396	484	569	654	
	1400					388	420	508	593	678	828
	1600							547	632	717	867

Fig. 2. Total weight of ACG Smoke fans incl. motor [kg]

Motor size	-90	-100	-112	-132	-160	-180	-200	-225	-250	-280
Weight	20	30	38	53	130	162	250	335	420	570

Fig. 3. Weight of motors for ACP and ACG Smoke [kg]

fan capacity with respect to pressure, air quantity, output and maximum speed (rpm).

A motor nameplate with relevant motor data, including enclosure class, is also provided.

2.2 Weight

The total weights shown in figs 1 and 2 apply to axial flow fans, types ACP and ACG Smoke.

The total weight is determined by the type/size of fan and the maximum size of the motor used, and is given in kg.

Fig. 3 shows the weights of the various motors. The motors are LOHER fire gas motors and the data shown, which are applicable for both ACP and ACG Smoke, are the maximum weights for four-pole motors.

2.3 Transport

During transport, care must be taken to prevent water, e.g. rainwater, from entering the motor or other sensitive components.

NovAx smoke fans, types ACP and ACG Smoke, are supplied on pallets or skids which allow fork-lift transport. The forks must be positioned beneath the base. The unit must be set down as slowly as possible on a soft surface. Impacts, vibrations and falls may lead to imbalance and deformation or other damage to motor bearings.

3. Storage

NovAx smoke fans can withstand outdoor storage for up to one month providing the packaging is intact. After removing the packaging, fans must be stored in a rainproof shelter.

If stored indoors, fans must be kept under well-ventilated conditions with no risk of condensation. Under such conditions, storage duration may be extended to six months.

The storage place must not be exposed to vibrations, which may damage the motor bearings. If stored for longer than three months, the impeller should be turned regularly by hand.

4. Installation

4.1 Mounting

NovAx axial flow fans, types ACP and ACG Smoke, are designed to operate in either horizontal or vertical position (the mounting position must be determined before drain holes in the motor are drilled).

ACP Smoke has free inlet and non-ducted outlet.

ACG Smoke has free inlet and ducted outlet (outlet guide vane assembly).

4.2 Before installation

Before installation, ensure that the impeller rotates freely in the fan housing, as far as possible with equal distance between blade tip and fan housing around the entire circumference.

4.3 Installation

Fans must always be installed in such a way as to prevent contact with rotating parts. Free inlets and outlets must be guarded by protective grilles. If ducts are connected, these must be provided with protective grilles on the side of the building.

The fan is provided with an arrow plate denoting the direction of air flow through the fan housing. During installation, ensure that the fan is oriented so as to provide the desired direction of air flow in the system.

The fan is best installed using special mounts (available as optional extras, fig. 4), but it may also be suspended by the housing flanges or in special hangers.

Hangers must not impede the free intake and discharge of air.

After securing the fan in position, check that the impeller rotates freely in the housing.

4.4 Mounts

Mounts for types ACP and ACG Smoke consist of two mounting plates (fig. 4 pos. 01 and 02). Beneath these, two C-profiles (pos. 03) must be fitted using bolts (pos. 05) and nuts (pos. 04).

The distance between the ends of the C-profiles and the mounting plates is determined by the fan type/size and motor size.

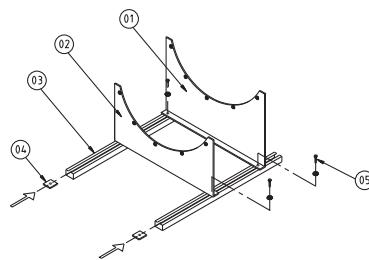

Fig. 4. Mount for type ACP Smoke

Mount the fan housing in the two flange holes in the mounting plates and fit the distance bush (fig. 5, pos. 07) by means of joining elements (pos. 08 and 09) between inlet cone and mounting plate (pos. 06).

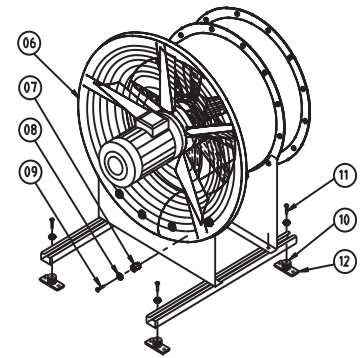

Fig. 5. Mount for types ACP and ACG Smoke 400-1120

ACP and ACG Smoke sizes 1250-1600 have circular fan housing. The housing is therefore installed using mount fittings (fig. 6 pos. 07A) and joining elements (fig. 6 pos. 08A and 09A).

The fittings must be attached to the back of the mount and fan housing. See fig. 6.

To prevent vibrations spreading from the fan to the surroundings, vibration dampers may be fitted between fan and underlying surface and flexible connectors may be fitted to the ducts behind the fan (available as optional extra).

Vibration dampers (fig. 5 pos. 10) should be fitted on the C-profile ends using bolts (pos. 11).

Base plates (pos. 12) for attachment to the foundation/floor should be fitted beneath the rubber dampers.

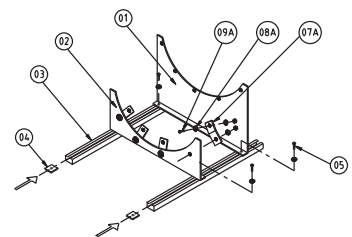

Fig. 6. Mounts for types ACP and ACG Smoke 1250-1600

The vibration frequency of the underlying surface must differ at least 20% from the fan speed.

If the motor is provided with condensation drain holes, the fan must be oriented so that the holes face downwards (are lowest).

It is of the utmost importance for the performance and sound level of the axial flow fan that the air flow is unimpeded and free of eddies.

4.5 Duct connection

NovAx ACG Smoke axial flow fans are

equipped with an outlet guide vane assembly with core. This improves fan efficiency and allows duct connection.

The duct on the outlet side of the fan must be designed to ensure a smooth flow of air without turbulence. Avoid, for instance, sharp bends or flexible connectors in the ducting immediately behind the fan.

ACP and ACG Smoke fans are prepared for circular duct connections on the outlet side.

Flanges supplied as standard comply with Eurovent 1/2.

Systems with higher vibration levels or more exacting performance requirements must be provided with expansion joints between the fan and duct, and the duct must not be supported by the fan.

It is important to provide sufficient free space for assembling and dismantling the system and to facilitate cleaning and maintenance.

4.6 Wiring

Important: Do not mount a frequency converter on a fan intended for smoke exhaust. The electric installation must be designed to bypass the frequency converter and run the fan at nominal speed in the event of fire.

Electrical connections must be made by an authorised electrician in accordance with current legislation. Power is connected via the motor terminal box as shown in the wiring diagrams in the terminal box cover.

Three-phase motors are connected as shown in the wiring diagrams in the terminal box cover.

For the connection of single-phase motors, see wiring diagrams for single-phase variable motors.

Having wired the motor terminal box, check that the direction of rotation of the impeller complies with the arrow plate fitted on the outside of the fan.

For reversible fans (alternating direction of rotation) a time delay must be provided to ensure that the impeller is stationary before restarting.

5. Start-up

5.1 Before start-up

Before start-up, check that the fan and duct connections are clean and free of tools and other foreign matter.

Also ensure that the electrical connections fulfil applicable requirements, that any

protective grilles on the fan inlet or outlet sides are correctly fitted, and that the direction of rotation of the impeller complies with the arrow plate (check by briefly starting the fan).

See fig. 7 pos. 01 and 02.

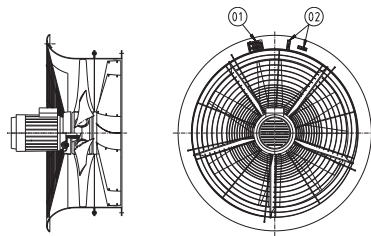

Fig. 7. NovAx ACG Smoke

5.2 Motors with Y/Δ start

The relay must be set to the calculated time.

5.3 Start-up procedure

- Start the fan.
- Check that no abnormal sound occurs.
- Check that the vibration level is normal. At operating speed, fan vibration must not exceed 7 mm/s rms* measured radially at two points with 90° offset and at the free shaft end of the motor. Otherwise, the fan must be rebalanced.

When fixed in position, the fan must not be operated if vibration levels exceed 11 mm/s rms*.

When freely suspended or mounted on vibration dampers, the fan must not be operated if vibration levels exceed 18 mm/s rms*.

* ISO 2954, Mechanical vibration of rotating and reciprocating machinery – Requirements for instruments for measuring vibration severity.

After thirty minutes of operation, check that the fan operates normally.

Important: The fan is designed for continuous operation. The following kinds of operation may cause fatigue break in

the impeller and endanger people.

- Operation with pulsating counter pressure - called pump mode
 - Operation with repeated starting and stopping
- If in doubt Novenco should be contacted to assess the suitability of the fan.

6. Maintenance

6.1 Safeguards prior to inspection and maintenance

Before inspecting or servicing the fan, it must be switched off and disconnected from the electrical system. Also ensure that the fan cannot be restarted unintentionally.

6.2 Fan housing

As standard, the fan housing requires no maintenance other than cleaning.

If the housing is painted, the surface should be checked regularly and repaired where necessary.

6.3 Impeller

The impeller (rotor unit) is supplied with the blades factory adjusted to the pitch corresponding to the desired operating point (pressure and air flow) at the fan speed in question. To ensure vibration-free operation the impeller has been carefully balanced in this position.

Vibration occurring during operation is usually the result of dust or dirt accumulating on the hub and blades, and will disappear after cleaning. Should this not be the case, technical assistance should be called in immediately as continued vibration will shorten the service life of the blades and motor bearings.

6.4 Motor

Normally, only the motor bearings require maintenance. This should be performed as described in the maintenance instructions for electric motors.

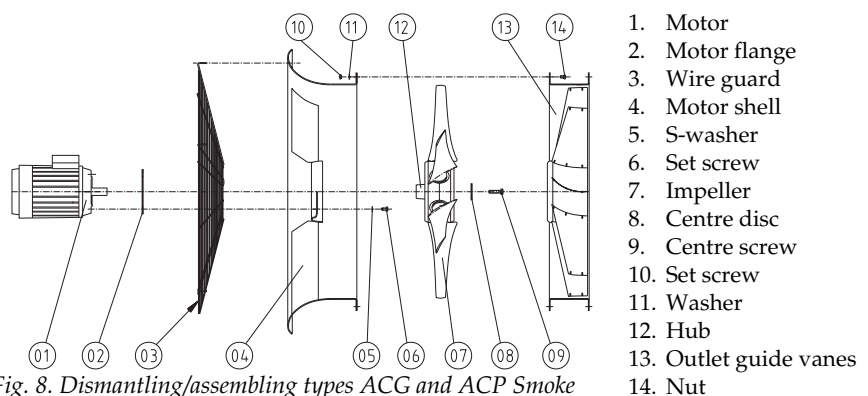

Fig. 8. Dismantling/assembling types ACG and ACP Smoke

6.5 Detaching the motor

Before motor detachment, disconnect the power supply and motor cable. Next, detach the ducts and outlet guide vane (fig. 8 pos. 13, 10, 11, and 14) on the outlet side.

Remove the impeller centre screw (pos. 09) and centre disc (pos. 08).

Detach the impeller using a puller secured in the two threaded puller holes in the hub boss (pos. 12).

Loosen the screws in the motor shell (pos. 05 and 06). The motor (pos. 01) and motor flange (pos. 02) can then be detached.

When dismantling the fan, be careful not to expose individual parts to impacts or other forces that might damage the motor bearings or fan parts.

6.6 Fitting the motor

After servicing is complete the motor must be refitted. Check that the motor flange (fig. 8 pos. 02) is correctly positioned and that the motor shaft is concentrically positioned in the fan housing before tightening the bolts (pos. 06).

Refit the impeller (pos. 07) on the motor shaft by means of a puller secured in the threaded hole on the motor shaft. Tighten the impeller hub against the motor shaft collar. Check that blade clearance is equal around the entire circumference of the housing. If this is not the case, adjust the motor position in the suspension system.

Now fit the centre screw (pos. 09) and centre disc (pos. 08). Replace lock washers and lock nuts when reassembling the fan. Finally, connect the motor cable in the terminal box (pos. 01) and any ducts and outlet guide vane (pos. 13).

To restart the fan, follow the procedure described in section 5. Start-up.

6.7 Blade pitch adjustment

The blade pitch is factory set using a special tool (fixture) to provide the output required by the customer.

If a different output is required, it is possible to alter blade pitch. This requires knowledge of the motor load and the max. permissible blade pitch in relation to the motor rating (in case of blade pitch increase).

Please contact Novenco before adjustment of blade pitch. Special tools for blade pitch adjustment and instructions for impeller balancing are available from Novenco.

A brochure describing the blade pitch tool and its use is available on request.

6.8 Fault finding

Possible operating faults are described in

the following.

Insufficient output

Blocked air supply on the inlet side.

- Damper closed
- Duct blocked
- Supply fan, if any, stopped
- Motor defective
- Motor cut out
- Incorrect direction of impeller rotation

Noise/vibration

- Bearings in electric motor defective
- Impeller out of balance
- Impeller worn/damaged
- Bolts/components loose
- Impeller blades have different pitch
- Fan operating in "stall" mode – this may damage the system and should be remedied immediately, see "Insufficient output".

7. Testing functionality and operational readiness

To maintain their fire approval, ACP and ACG Smoke fans must be tested every three months with respect to functionality and operational readiness.

If ACP and ACG Smoke fans are also used for ventilation purposes, such tests need only be performed at six-month intervals provided the fan is started at least once a day by means of a time switch or carbon monoxide sensor.

7.1 Periodic inspection

NovAx smoke fans must always be maintained in proper operating condition. To ensure satisfactory operation and long service life, the fans should be inspected every six months.

Such inspection should include the following.

- Measurement of power consumption
- Measurement of fan housing vibration
- Control of fixation bolt torque and, if necessary, readjustment
- Visual inspection of impeller, housing and wiring
- Cleaning
 - Use compressed air to clean the inside
 - Use water to clean the outside

It is recommended that a log be kept of all values and observations.

8. Sound

The sound generated by the fans depends on installation and operating conditions, and general data on sound generation is therefore unavailable.

Please refer to the NovAx catalogue material and the AirBox program for calculation of specific sound emissions.

9. Declaration of conformity

Novenco Building & Industry A/S
 Industrivej 22
 4700 Naestved
 Denmark

hereby declares that Novenco axial flow fan types ACP Smoke 400-1600 and ACG Smoke 400-1600 have been manufactured in accordance to the below directives of the European Council and that they comply with the below standards and regulations.

Directives

- Machinery 2006/42/EU
- ECO design 2009/125/EU and regulation 2017/1369/EU
- EMC 2014/30/EU
- LVD 2014/35/EU

Applied standards and regulations

- ANSI/AMCA 300-14
- EU regulation 327/2011
- DS/EN 1037 + A1:2008
- DS/EN ISO 1461:2009
- DS/EN 1886:2008
- DS/ISO 2954:2012
- DS/EN ISO 5801:2017
- DS/EN ISO 9001:2015
- EN ISO 12100:2011
- DS/EN 12101-3:2015
- DS/EN ISO 12499:2009
- DS/EN ISO 12944-2:2017
- ISO 13348:2007, class AN3
- DS/EN ISO 13857:2008
- DS/EN ISO 14001:2015
- DS/ISO/TR 14121-2:2012
- ISO 14694:2003
- DS/EN 16798-3:2017
- DS/ISO 21940-11:2016
- DS/ISO 21940-14:2012
- DS/EN 60204-1:2006 + A1:2009
- DS/EN 61000-6-1:2007
- DS/EN 61000-6-2:2005
- DS/EN 61000-6-3:2007 + A1:2011
- DS/EN 61000-6-4:2007 + A1:2011
- DS/EN 61800-3:2005, class C2 + A1:2012

It is a condition that Novenco installation instructions have been followed.

Naestved, 1.08.2020

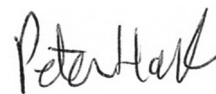

Peter Holt
 Technical director
 Novenco Building & Industry A/S

Pure competence in air.

Building & Industry

NOVENCO 

SCHAKO Group

WWW.NOVENCO-BUILDING.COM